

Bartłomiej Gawin

Department of Business Informatics, University of Gdańsk, Piaskowa 9 Street, Sopot, Poland
e-mail: bartlgaw@wp.pl

Jerzy Roszkowski

Management Systems Consulting, Poznańska 28/1 Street, 93-234/ódź, Poland
e-mail: jerzy.roszkowski@neostrada.pl

Extension the capacity of the cellular network ó process **simulation and optimization**

Abstract

The most desirable way to lead the organization (including the telecommunications company) is business process management. Adaptation and implementation of process-driven approach requires enterprise description, using models of business processes. The article presents data collection methods and then simulation and optimization of business process, which has been implemented in workflow system within technical area of mobile operator in Poland. Data extraction has been performed using workflow mining techniques and ProM¹ environment, coming from Eindhoven University of Technology (Holland). Mined process model and parameters have been transformed to BPMN notation and then implemented in ARIS Business Simulator tool. After this, number of business process simulations has been performed. Obtained simulation results has been analyzed, which resulted in the identification of bottlenecks in the process. Modifying the activity durations and the number of employees involved in the process, new business conditions have been proposed, that would ensure elimination of bottlenecks and realization of the same number of instances in a shorter period of time.

Keywords: process mining, process simulation and optimization,

1. Introduction

W.E. Deming has presented fourteen key principles for company management and one of them sounds: "(...) 85% of the reasons, causing failure to the customer's requirements, relates to deficiencies in the work system and business processes, not to employees. The role of management is to improve processes than constantly remind staff that should worked better (...) [1]". Mentioned thesis, which can be seen as a recipe to solve many organizational problems in companies, tends to perform the following activities: identification of business processes in the company, then their improvement, modification and then long-term control. Implementation of listed activities introduces a new model of corporate governance, called the business process management or procedural orientation.

Business process management is increasingly being used to lead the organization, because of great possibilities for the company's competitiveness and dynamic growth in a changing business reality. The idea of adapting business process management involves the transformation from the vertical, functional organization to the horizontal, process oriented

¹ The IT environment, applied to analyze event logs from workflow system database. The ProM provides several algorithms for investigating the registry instances of business process.

company². In the first case, the organizational units focus only on assigned task. Lack of an overview of the company significantly complicates the flow of information, in extreme cases can lead to duplication of performed activities. The horizontal orientation means the overall view to the organization, treated as a multidimensional set of related and overlapping layers (areas and subsystems), participating in various processes [8]. The management of these processes means auditing control flow, data and information flow, from the beginning to the end of workflow paths, regardless of operation areas and organizational structures with allocated tasks.

Business process management approach uses IT tools to support simulation and optimization of business processes. This article provides simulation and optimization of business process, which has been implemented in a telecommunications company many years ago and concerns to increase the capacity of the cellular network. The main goal of this process is customer oriented and concerns data transfer increase (fast Internet through mobile network) and provides possibilities to carry more voice calls in a given geographical area. In fact, this process is coordinated by the workflow system: people, who are responsible for designing the mobile network, make up the concept how to increase the capacity. Then, using the workflow system, prepared project (attached files, descriptions, links to external network planning systems) flows through a company structure. Assigned tasks are executed in order by people responsible for operation and maintenance specific areas of the telecommunications network. Every execution of business process, called "business process instance" is saved under the unique identification number in workflow database. Every process instance consists of several steps (activities), which are hierarchically stored in workflow database. Single activity has set of related data: detailed activity description (what has been done ?), durations of activity, people identifiers (who has carried out the activity ?) and sometimes additional information.

The main goal of the article is to present the business process simulation, which was performed in order to optimize business process execution time and utilization of human resources. This article has been divided into the following parts: the second chapter contains the UML activity diagram and a description of the business process. The third part presents the "workflow mining" algorithms, used to develop the simulation model parameters. The fourth chapter describes the transformation of the UML activity diagram to BPMN diagram, which, enriched with the model parameters, was used for business process simulation and optimization (chapter five). Part Six concerns the analysis and interpretation of the results, and the entire study are summarized in chapter seven.

2. Description of the business process

A major difficulty, encountered during preparation a business process description, was the lack of its theoretical model. The process has been implemented for commercial usage in the enterprise about 10 years ago and the person, responsible for it, has developed only a general description of the tasks to be performed. Therefore, the actual path of the process flow, coordinated by the workflow tool, has been formed independently over the years, taking the shape automatically, depending on the business and technical conditions. Based on the process instance from the database and using the innovative method "workflow mining" with algorithm "Heuristics miner", business process graphical model has been created. Mentioned technique "workflow mining" and a tool ProM for its practical usage have been developed by the scientific center from Eindhoven University of Technology. The idea of the algorithm bases on hierarchical analysis of all instances and their various stages in database. The

² According to Boston Consulting Group (international company, providing services in strategic consulting) there are two extreme models, reflecting the maturity of company's process orientation,; <http://www.bcg.com/>

algorithm of reviewing the event log returns the result as a graphical process model - diagram "Heuristics netö. In order to present a business process, obtained diagram has been converted to more popular UML (Unified Modeling Language) activity diagram, as shown in Figure 1:

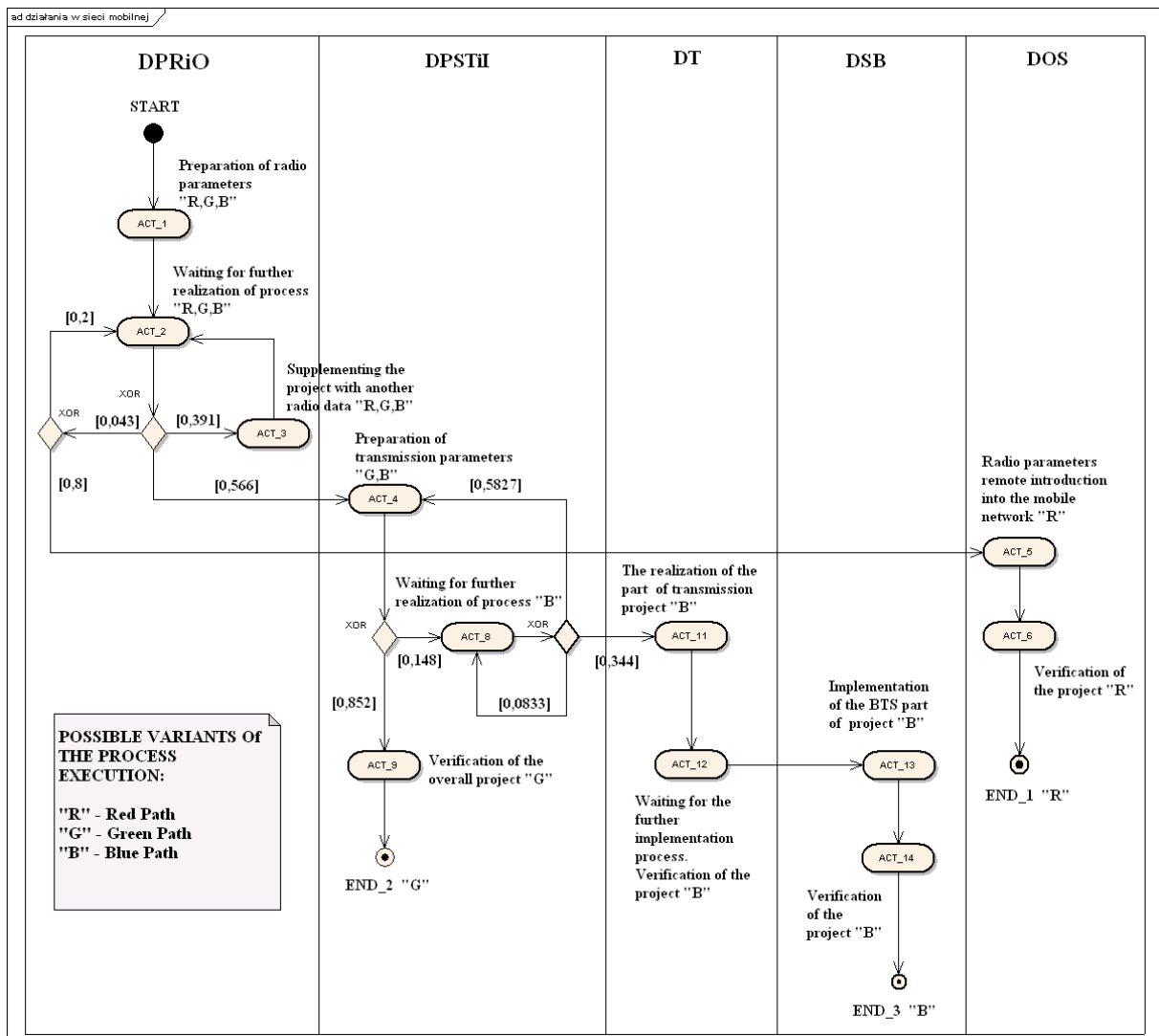

Figure 1: Process model to increase the capacity of the cellular network

Table 1 shows the names of organizational units involved in the process and overall scope of their activities:

Table 1: Technical group participating in the process

Group name	Overall scope of activities
DPRiO	Deciding on the need to increase network capacity. Preparing the parameters for the telecommunication equipment, responsible for increasing the mobile network capacity
DPSTii	Deciding on the need for increased data rate transmission between the operator's devices. Preparing the parameters for these modifications
DT	The implementation of telecommunications projects
DSB	The implementation of telecommunications projects
DOS	The implementation of telecommunications projects

UML activity diagram from figure 1 has one beginning of the process (point START) and three possible termination points (END_1, END_2 and END_3). They are achieved depending on the variant of tasks execution in the process. Three paths, possible to achieve during control flow through set of activities (oval symbols ACT_nr) is indicated by the letters "R-Red, G-Green, B-blue" (the colors are visible in the Power Point presentation.) These letters are plotted close the stages, that are carried out during the process control flow. If a given stage (for example ACT_1) has been executed in each variant of the process, then there are three possible letters close to ACT_1, describing the executed variant (R, G, B). UML activity diagram has been divided into five partitions, which reflect the tasks assignment to dedicated organizational group. Names of organizational units are placed on top of each partition. There are no parallel runs in the process. Identified decision points are indicated by the diamond symbol with outgoing control flows, which have been described by values in brackets, reflecting transfer probabilities from the decision point.

As mentioned previously, the process of increasing the capacity of the network can be implemented in three variants. Implementation of the path depends on the conditions described below:

1. Control flow R (Red): Mobile network capacity extension only by remote parameter modification of telecommunication devices. No need for physical modification of the network; people from DOS group connect remotely with the hardware and set parameters according to received project.
2. Control flow B (Blue): Network capacity extension for the subscriber, associated with the need to increase the capacity of the network operator. This is the longest of all the possible paths and involves the largest number of teams.
3. Control flow G (Green): This variant refers to partial preparation to increase the capacity. If there is no equipment on sites, DPRiO and DPSTiI groups prepare the conception of extension and the project waits for equipment.

Table 2 shows the detailed activities descriptions and activity assignment to possible variants:

Table 2: Activities descriptions and activity assignment to possible variants

Activity	Description of activity	Path R (red)	Path B (blue)	Path G (green)
ACT_1	Preparation set of radio parameters for telecommunications equipment, which are responsible for increasing the capacity of the mobile network. At this stage the decision is taken: is it enough only implement parameters in the network (red route), or to make additional transmission project and execute it (blue route) or (green route) only preparation is possible.	X	Y	Z
ACT_2	The overall project is assigned to DPSTiI and waits for further implementation.	X	Y	Z
ACT_3	Sometimes project created by DPRiO is modified at the design stage and must be improved or supplemented.	X	Y	Z
ACT_4	Preparation a transmission project, in order to ensure adequate bandwidth between telecommunication devices on the operators network. Sometimes, for the extension of transmission routes, the physical connections of devices in the field are required.		Y	Z
ACT_5	DOS performs tasks from DPRiO: parameters are introduced into the network remotely.	X		

ACT_6	Parameters are implemented. ACT_6 activity can be considered as verification of the modifications made in the network.	X		
ACT_8	Developed projects are assigned to DT group and wait for further implementation. XOR operators (to ACT_4 or ACT_8) reflect the need for improvements, which sometimes come at the stage of waiting (in ACT_8 stage, tasks are not performed, but analyzed)		Y	
ACT_9	DPSTiI group has completed its part of project. The conception of "network capacity extension" waits for new network equipment, but workflow task is ended.			Z
ACT_11	DT group implements the project from DPSTiI; creates logical transmission circuits, configures transmission equipment and prepares physical connections in the field.		Y	
ACT_12	DT group transfers the project to DSB group. Over a period of time, the project is not executed, but analyzed		Y	
ACT_13	DSB group performs physical connections between devices, implements parameters from DPRiO		Y	
ACT_14	All actions have been completed. The process is verified and expects to complete the project execution in the workflow system		Y	

3. Data preparation for the process simulation and optimization

ARIS Business Simulator (ver 7.1) environment for business process simulation, requires the following input data:

- BPMN (Business Process Modeling Notation)³ model, which graphically presents business process and consists of:
 - organizational units (diagram allocation functions),
 - possible variants of the process flow (set of activities, connected with control flow arrows),
 - set of logical operators (XOR, AND, OR),
- Business process parameters:
 - the average frequency of the input event / time,
 - relational operators (the probability for each of the outputs from decision points),
 - duration of the activity,
 - static waiting time for static moments in process execution.
- The degree of human resources involvement (number of participants in the process / number of persons employed in the organizational unit).

The data to simulate the process model has been developed, like the graphical UML activity diagram, using the "workflow mining" algorithms. Table 3 presents a set of required data simulation, completed with used "workflow mining" algorithms names and descriptions.

³ Business Process Modeling Notation (BPMN) - is a graphical representation for specifying business processes. BPMN was developed by Business Process Management Initiative (BPMI), and is currently maintained by the Object Management Group

Table 3: Required simulation data and algorithms used in their estimation

Simulation parameter	The algorithm used to estimate the parameter	Brief description of the results
Process diagram	<i>Heuristic Miner</i>	-graphical model preparation
Responsible groups, Number of people involved in single activity	<i>Organizational Miner</i>	- verification of workers identities, belonging to organizational units, - verification of tasks, performed by an organizational unit - verification the number and identities of processes participants
Activity time, Weights in decision points	<i>Performance Analysis with Petri net</i>	- time parameters and control flow weights from decision points

To optimize the process, the total number of persons, employed by the various organizational units, is also required. According to table 4, the value of parameter "Total number of people in the group" has been estimated as general environment knowledge, where the process has been implemented. The last parameter for the simulation is "The average frequency of the input event / time". The value is 71 process executions per one year, but last of them has finished 2,5 months after the last day of year. "The average frequency of the input event / time" value has been estimated by ProM tool, which, in addition to "workflow mining" analysis, provides also general information about events log.

As mentioned earlier, "workflow mining" algorithms are carried out by ProM tool, which, like the "process mining" conception, has been developed at Eindhoven University of Technology. Data preparation for analysis requires an adjustment of their format from the tabular data (obtained from a database using structured query language SQL), to MXML format (Extensible Markup Language), which is the input file format for ProM environment. Due to the complexity of the adaptation, this paper presents only the results of the "workflow mining" algorithms and detailed transformation process has been described in the accompanying literature [3]. Table 4 presents the estimated values of parameters for process model simulation:

Table 4: Values of simulation parameters (before optimization)







ACT Nr	Avg duration (ddd.hh.mm.ss)	Responsible group	Nr of people involved	Total nr of people in the group
ACT_1	000:00:02:36	DPRiO	3	7
ACT_2	010.03.08.49	-	-	-
ACT_3	000:00:09:19	DPRiO	6	7
ACT_4	003:09:25:37	DPSTiI	4	6
ACT_5	000:00:23:25	DOS	2	9
ACT_6	000:12:06:19	DOS	2	9
ACT_8	002:00:14:00	-	-	-
ACT_9	013:07:22:22	DPSTiI	3	6
ACT_11	000:00:26:22	DT	4	6
ACT_12	104:03:03:57	-	-	-
ACT_13	000:00:00:48	DSB	1	13
ACT_14	014:17:09:10	DSB	1	13

Based on above values can be notice, that activities ACT_2, ACT_12 ACT_8 do not use human resources for execution. This is due to the fact, that there are steps in the process, reflecting waiting moments for verification and taking up the project tasks by another group.

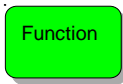
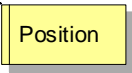
4. Business process transformation from UML activity diagram to BPMN diagram

ARIS Business Simulator (ver 7.1) environment requires BPMN process model as input format for simulation purpose. Table 5 presents, according to the nomenclature of ARIS, symbols and descriptions of charts in BPMN diagram model:

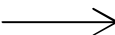
Table 5: BPMN graphical symbols according to ARIS nomenclature

Concept	Graphical symbol	Semantic meaning
Business process/Business Function		Simple activity (or integrated sequence of activities) performed in order to produce an end result (a product or a service). Business Function means elementary Business Process.
Organization unit/position		The symbol of organizational unit, which performs a specific role within the process
Logical operator "OR"		Logical operator "OR" connecting two or more logical objects
Logical operator "XOR"		Logical operator "XOR" connecting two or more logical objects
Input (start) Event		The symbol of event causing "start" each activation of simulation
Control transmission		A graphical symbol connecting business functions which indicates the order of performance thereof (otherwise: control flow).
Terminate (end event)		The symbol of event causing "end" each activation of simulation

To perform the transformation from UML activity diagram to BPMN process model, following rules have been developed:

- every activity (UML) has been replaced by function
- multiple entry to the processes have been combined with operators "OR",
- decision points have been replaced by XOR operators,
- partitions from UML diagram, reflecting organizational units, have been replaced by ARIS process allocation diagrams, and the example has been shown on figure 2:

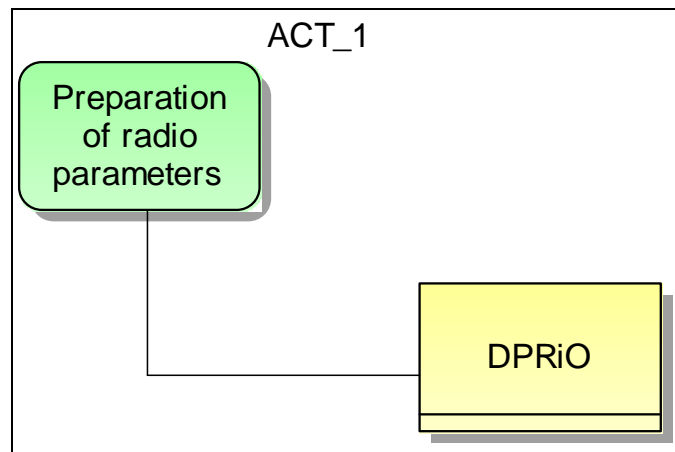

Figure 2: Example of process allocation diagram

Because of size and usefulness during interpretation of simulation results, completed BPMN diagram is shown in the next chapter on Figure 5.

Based on BPMN model and process parameters, 71 process executions have been performed. On-line observed process simulation (animation) provides numerical results of the current simulation status. Every function from business process model parses process instances and dynamically provides information about current status of simulation. Figure 3 shows ARIS way of presentation progress of simulation. Every function is surrounded by numbers, presenting simulation results, as described on figure 3:

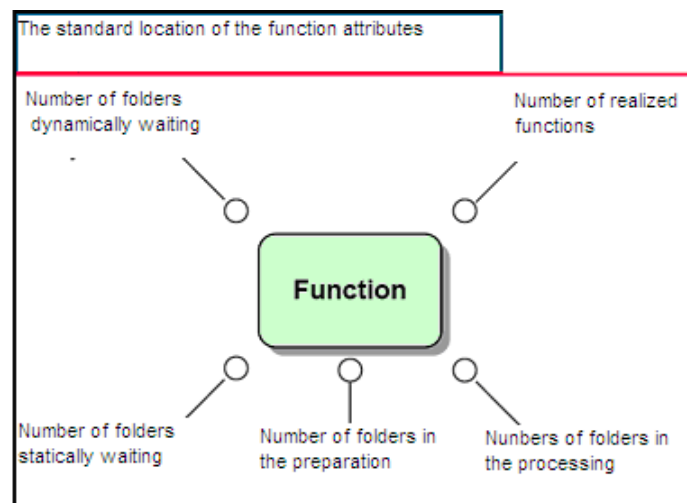

Figure 3: The meaning of the individual numbers, describing simulation progress



The meaning of the various descriptions in Figure 3 is as follows:

- number of folders dynamically waiting ó number of instances of processes, waiting for execution due of human resource absence (eg. in the same time, needed resources are busy because of handling other processes),
- number of realized functions ó number of instances, which has been carried out and completed,
- number of folders statically waiting ó number of instances of processes that can not be done; they are not waiting for resources, but for trigger from decision point XOR or parallel AND flow,

- number of folders in the preparation ó number of instances of the process, which are in preparation status (some processes require preparation time to run them),
- number of folders in the processing ó number of instances of processes, which are currently in processing status.

5. Business process simulation and optimization

Business process simulation and optimization has been performed as number of iterations, where the main goal is concerned to select optimal duration time of every step in the process and selecting the optimal number of human resources in such way to perform 71 process executions and complete them in just one year. During time and resources optimizing it has been taken into account, that number of employees is limited (in every organizational unit) and there are some time constraints due to the nature of functions.

Figure 4 presents EPC diagram⁴, which reflects developed method of iteration procedure to collect simulation data and then carry out business process simulation and optimization.

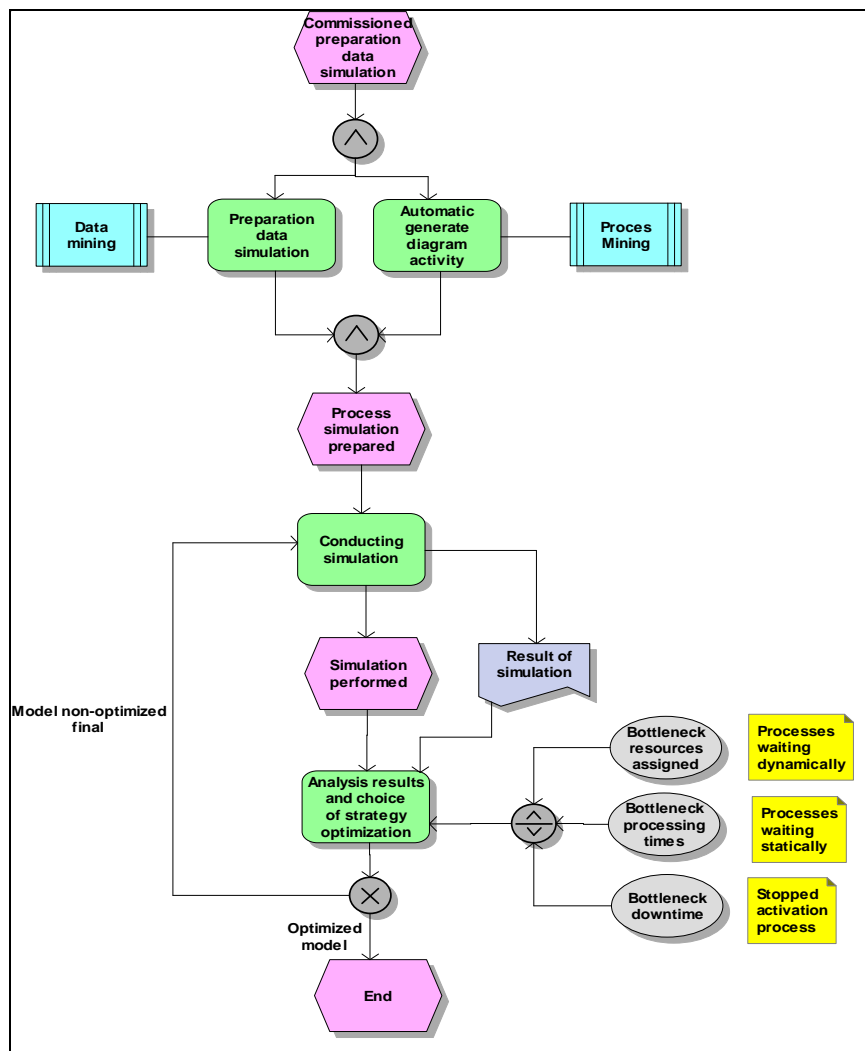

Figure 4: Developed method of procedure to carry out whole study

⁴ EPC- Event Process Chain ó type of flowchart, which presents work order during preparation and execution case study (EPC has been developed by ARIS [9])

As shown on figure 4, simulation and optimization study consists of several steps, some of which are repeated in an iterative cycle. At the beginning, UML activity diagram, obtained with some exploring methods from workflow system database, has been converted to BPMN form. Some additional model parameters, which are also obtained with exploring methods, are placed in to the simulation BPMN model. Then the simulation process has been carried out and first analysis has detected three sources of bottlenecks:

- **"bottlenecks" associated with the allocation of resources** ó human resources are insufficient; they are invoked by the currently processing instance but resources are busy. Therefore, they can not be used until the end of processing another process execution. As the result, on the simulation model are created process instances called "*dynamically waiting*" for the execution until the release of resources. The optimization solution is to increase resources in order to eliminate "*dynamically waiting*" processes.
- **"bottlenecks" associated with function processing time (function execution time)** ó exists, if possibility to increase the resources has been already exhausted and the only solution is to reduce the execution time (but according to business possibilities). As the result, on the simulation model are created process instances called "*statically waiting*". Optimization solution is to reduce the implementation time of such processes, in order to eliminate "*statically waiting*" processes.
- **"bottlenecks" associated with downtime (which means to stop the activation process instance)** ó it results as elongation of total duration of the simulation. The solution is optimize bottlenecks described above in order to reduce downtime

Simulation results have been subjected to optimization strategy, which means model parameters modification (execution times, human allocations) in order to reduce detected bottlenecks and finish simulation (all process instances executions) after 365 days. Figure 5 presents BPMN process model, which has been drawn with ARIS tool [9]. Additionally, BPMN diagram provides last iteration results with reduced numbers, surrounding every function in process.

There was a significant complication of the optimization, because the three types of bottlenecks are interdependent, such as the elimination of "*waiting dynamically*" instances has created "*waiting statically*" instances in another model place. Therefore, the optimization study has been performed as set of described below iterations.

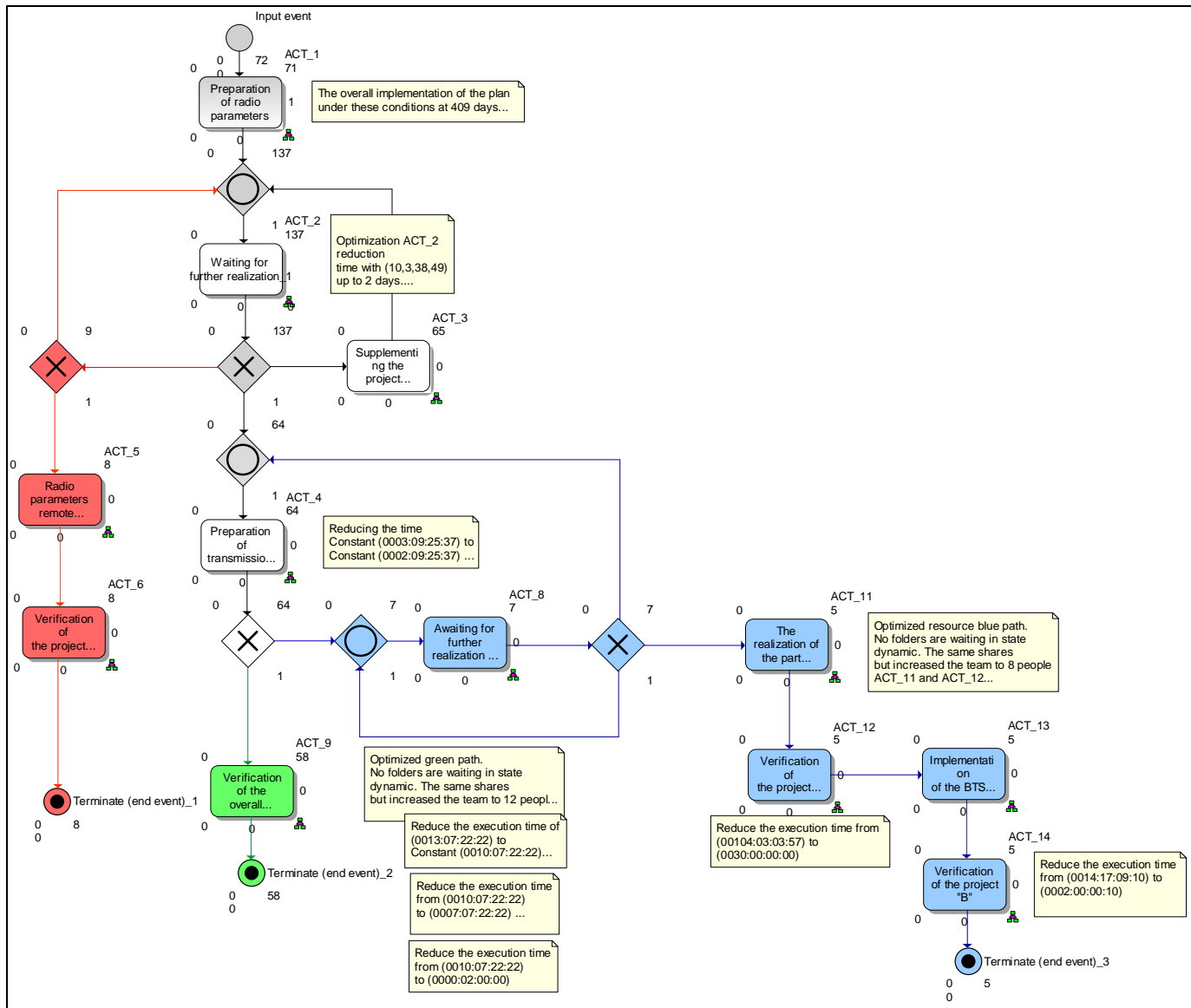

Figure 5: BPMN process model and simulation results

Optimization of the process has been performed as set of iteration:

- **Iteration_1**

First simulation based on initial input data: the main bottlenecks are on the main branch because of insufficient resources (workers from group DPSTiI). These resources are required in the same time for functions: ACT-4 ACT-9. Insufficient resources create a "dynamically waiting processes" bottleneck. According to table 4, it is possible to engage more people from the group to execute ACT-4 and ACT-9.

- **Iteration_2**

Second simulation has been executed after increasing people from DPSTiI and reducing the execution time for ACT-9. In this way, "green path" has been completely optimized (no waiting instances). The duration time, from creation to finishing 71 instances, has been reduced from 650 days (result from Iteration_1) to 409 days. But the plan is achieved 365 days to completely parse all instances through all possible paths.

- **Iteration_3**

The waiting time for ACT-2 and processing time for ACT-4 have been reduced. It has reduced *statically waiting* instances on ACT_2, but this solution did not give satisfactory results according to completing simulation in one year.

After set of iterations, desired result has been achieved. It means, that using available resources and reducing execution and waiting times for functions (in accordance with business rules), all instances have been finished in 365 days. Additionally, *waiting instances* has been also reduced, as shown on figure 5. It's difficult to describe all optimization moves, because changing allocations and times caused, that statically and dynamically waiting instances have disappeared in one place, but appeared *around* functions in different stage of model.

6. Statistical simulation results

Except process simulation dynamic results, it's also possible to observe statistical results in graphic form. There are some examples of them, created for the initial and final iteration of the optimization route.

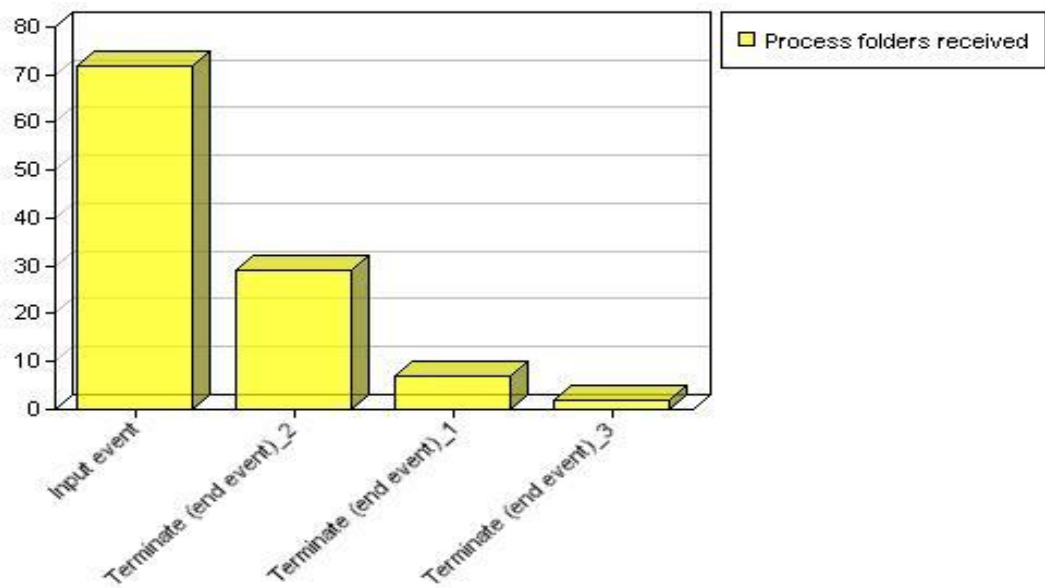

Figure 6. Iteration_1: The simulation does not stop within the required one year time and sum of instances in Terminate_1, Terminate_2, Terminate_3 points is less than the number of input event. It means lots of processing instances.

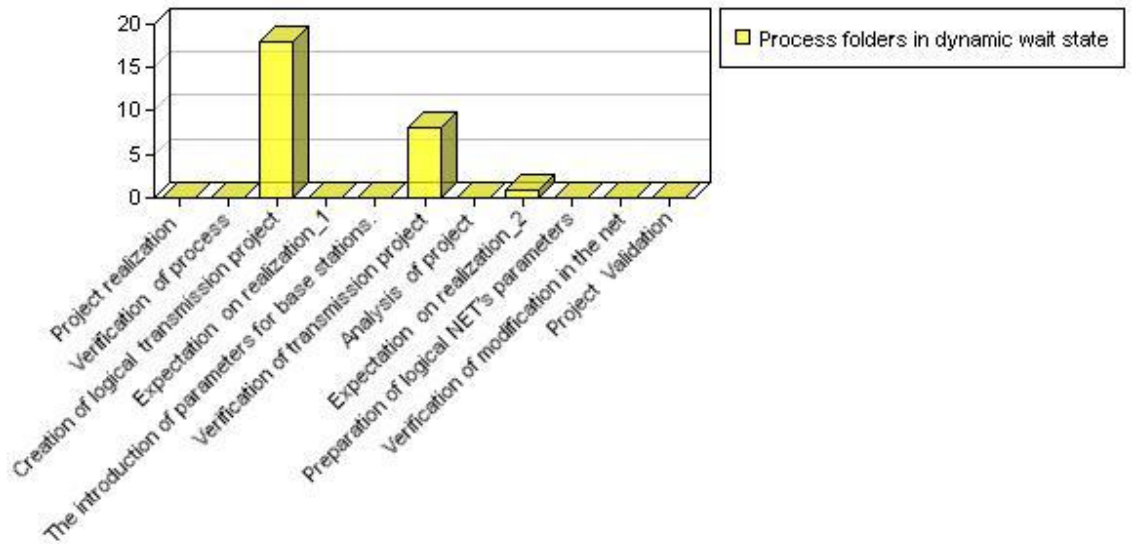

Figure 7. Iteration_1: Resources are not properly allocated, so there are many processes in the "dynamic waiting state".

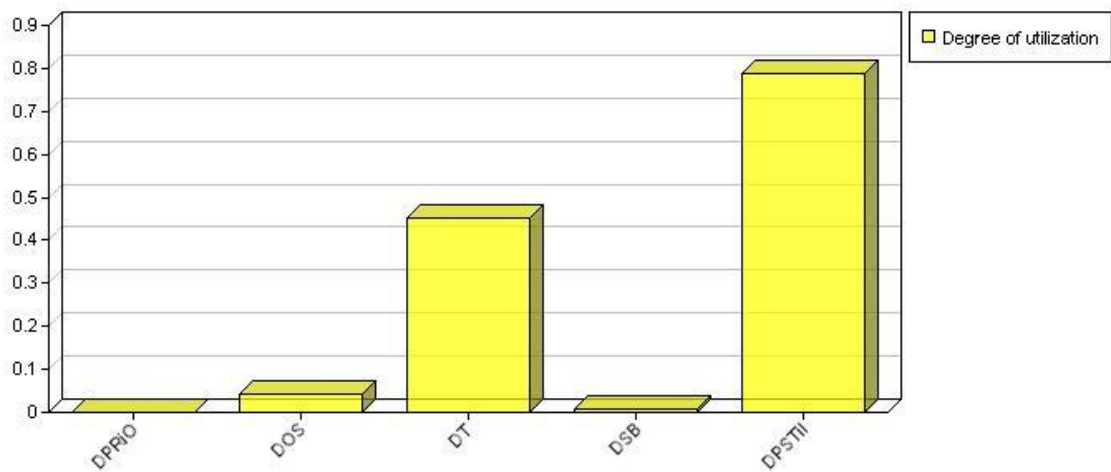

Figure 8. Iteration_1: The initial level of resource utilization.

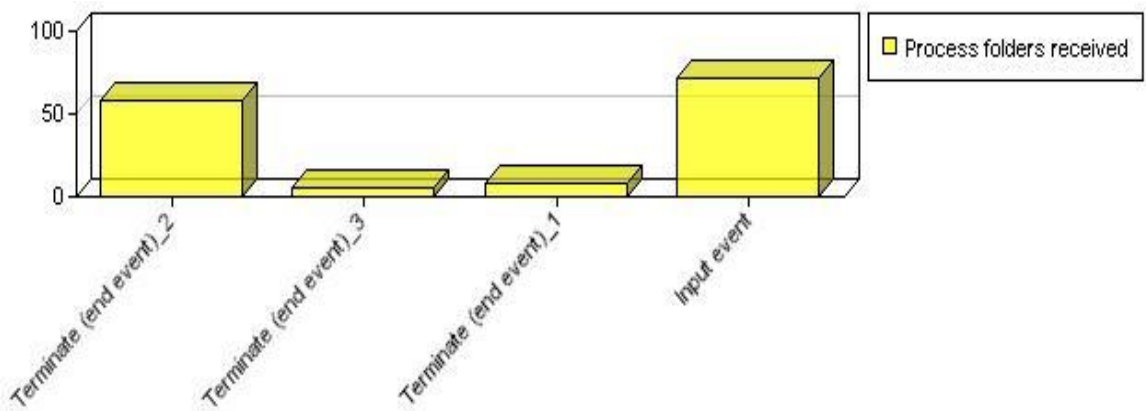

Figure 9. Iteration 6: Simulation ends in 1 year. Sum of instances in Terminate_1, Terminate_2, Terminate_3 points is the same as the number of input events.

7. Summary

Workflow mining algorithms allowed to estimate business process model and its parameters, necessary for simulation and optimization. It must be remembered, that the durations of individual activities that workflow system backs up in the database, reflect only the service time of tasks in the system, which may differ from the actual execution time of these tasks. It happens, because taking up, transfer and closing tasks in workflow system is carried out manually by the staff by clicking the appropriate button on the form workflow applications form. It's very difficult to control real execution time in relation to workflow system execution time.

Performed first simulation provides bottlenecks, which caused very long total execution time of instances (much longer than one year). Optimization method, executed as set of iterations, has allowed bottlenecks elimination and reduction total execution time to one year. Set of iteration has been performed with real business condition, which means number of employed people and function time-execution constrains. The next step of the study concerns simulating costs, connected with extension the capacity of the cellular network

8. Literature

1. DEMING, W. E., (1986), *Out of the Crisis*, MIT Press
2. DEO. N., (1980), *Teoria grafów i jej zastosowania (ang. Graphs: theory and applications)*, PWN
3. GAWIN B., (October 1-2 2009), *Processes mining techniques and organizational aspects of a workflow database*, The 8th International Conference on Perspectives in Business Informatics Research, Kristianstad University College, Sweden
4. ROSZKOWSKI J., (2004), *Analiza i projektowanie strukturalne (ang. Structural analysis and design)*, Helion
5. ROSZKOWSKI J., (2007), *The Formal Approach to Definition of the Requirements for the Needs of Computer Application Selection and Implementation*, Proc. of the 16th International Conference on Systems Science ICSS
6. ROSZKOWSKI J., KOBYLICKI A., (October 1-2 2009), *Quality Management Reference Models for Business Intelligence ó Class Systems*, The 8th International Conference on Perspectives in Business Informatics Research, Kristianstad University College, Sweden
7. ROSZKOWSKI J., (2010), *The simulation of processes in the integrated computer environment in the TELCO sector*, Proc. of the 7 Symposium ó Modeling and Computer Simulation, ód, College of Computer Science
8. RUMMLER G.A., BRACHE A.P., (2000), *Podnoszenie efektywno ci organizacji. Jak zarz dza biaymi plamami w strukturze organizacyjnej (ang. Improving the efficiency of the organization. How to manage white spots in the organizational structure)*, PWE Warszawa
9. SCHEER A.W., (2000), *Business Process Modeling*, Springer-Verlag, Berlin, Heidelberg, New York.